

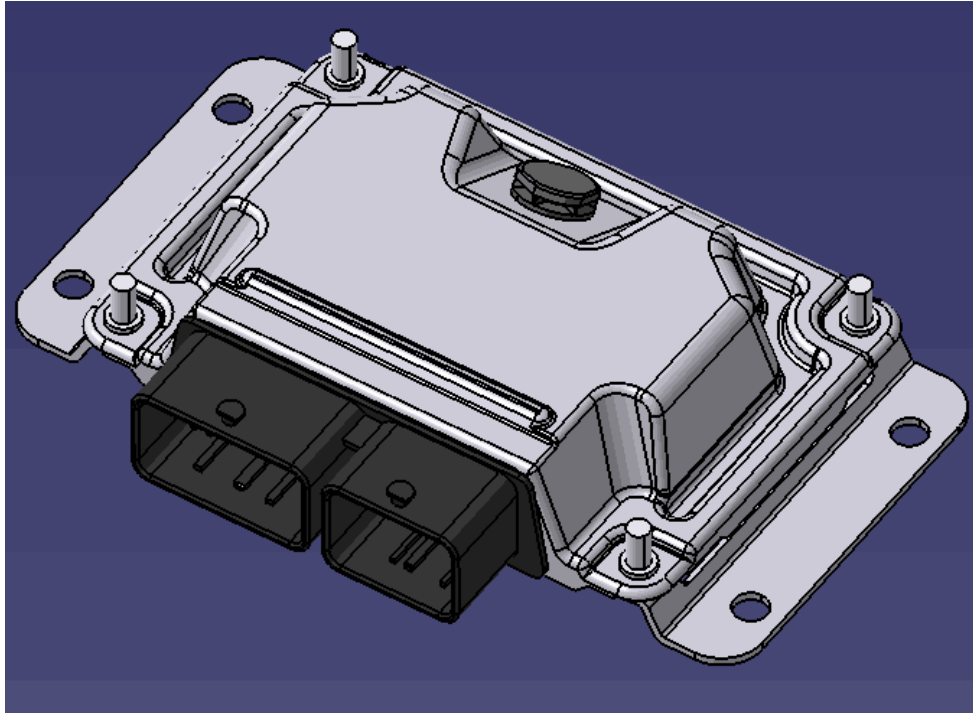

## VCU Specification

### Model Mo. AT-VCU-3000



#### Features:

1. Voltage: 12V
2. Dimensions(mm): 180.5\*123.2\*37.6
3. Operation Temperature: -40°C~80°C
4. IP Protection: IP67
5. Weight: 0.45KG
6. Average life time without error $\geq$ 15000 hours
7. Compatible of CAN2.0B ISO11898-2003



## Contents:

1. Product Structure .....	3
1.1 Product Shape Digital Model .....	3
1.2 Size Drawing.....	3
1.3 Product Weight.....	4
2. Hardware Description Of The Product .....	4
2.1 Operating Environment Conditions .....	4
2.1.1 Temperature .....	4
2.1.2 Humidity .....	4
2.1.3 Protection Level .....	4
2.1.4 Hardware reliability .....	4
2.2 Supply conditions.....	6
2.2.1 Main supply design .....	6
2.2.2 Sensor supply .....	7
2.3 The performance of Hardware .....	7
2.3.1 Microcontrollers .....	7
2.3.2 I/O .....	8
2.3.3 ADC.....	8
2.3.4 Powertrain Switch .....	9
2.4 The performance of Communication interface .....	10
2.4.1 CAN .....	10
2.4.2 Other communication interface.....	10
3.Product bottom software description .....	10
4. Product software development tool chain.....	11
4.1 Compiler.....	11
4.2 Debugger .....	11
4.3 Calibration.....	11
4.4 Date monitoring analysis.....	12
4.5 Application update .....	12
4.6 TOOL .....	12



# 1. Product Structure

## 1.1 Product Shape Digital Model

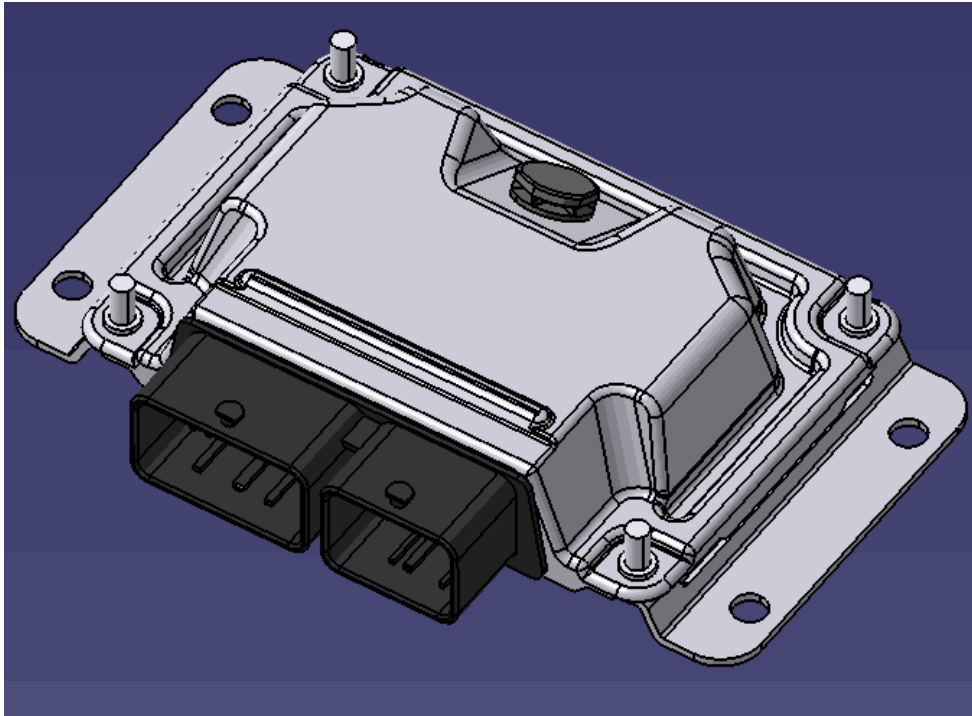

The product adopts material 5352AL stamping process, and the mounting bracket can be independently designed according to customer requirements.

## 1.2 Size Drawing

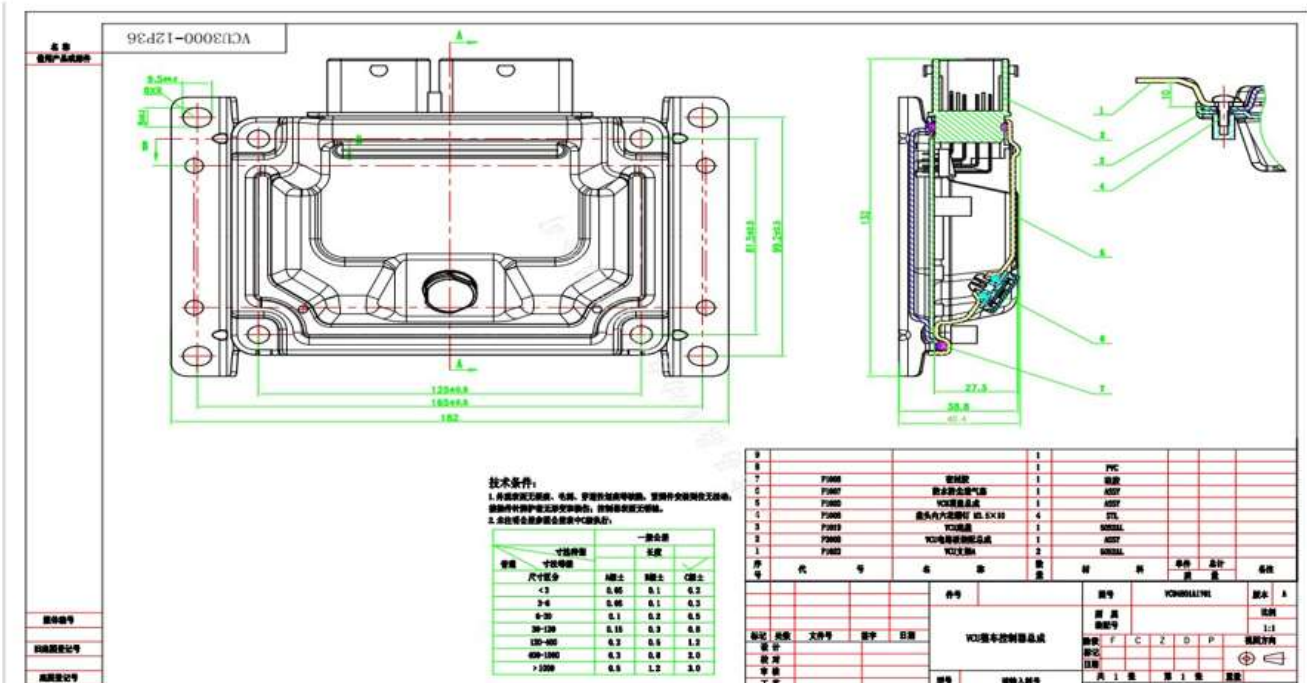

- product Overall size: 180.5\*123.2\*37.6 mm;
- The lateral and longitudinal dimension of the installation hole : 59mm、165.5 mm.
- Weight: 0.4KG



## 2. Hardware Description Of The Product

### 2.1 Operating Environment Conditions

#### 2.1.1 Temperature

The VCU temperature range: -40~85°C.

#### 2.1.2 Humidity

VCU can work normally when the relative humidity is not more than 90% and its surface temperature is lower than the dew point (condensation on the surface).

#### 2.1.3 Protection Level

VCU should meet the IP protection level IP67 of ISO 20653-2013。

#### 2.1.4 Hardware reliability

4. Reversed voltage protection;
5. Over voltage and Surge protection;
6. ESD protection;
7. Over voltage, over current and over temperature protection for power devices;
8. Short to GND and Vbat and open load protection and diagnosis for I/O Pins
9. All sensors have its default state when in error.
10. Average life time without error $\geq$ 15000 hours

NO	Test item	Test explanation/ test standards	Target
1	High /Low temperature storage	QC/T413	-40°C/2h 65°C/2h
2	High /Low temperature work	QC/T413	-40°C/8h 85°C/8h
3	Temperature cycling test	QC/T413,GB/T2423.22	-20~55°C/10h
4	Vibration test	QC/T413,GB/T2423.10	XYZ direction/sweep10~15Hz,1oct/min; 25~500Hz,15m/s <sup>2</sup> ,1oct/min
5	Salt mist test	QC/T413,GB/T2423.17	33~37°C/5%/PH6.5~7.2/16h
6	Operation voltage	ISO 16750-2-2010	9V-18 Voltage, meet functional state A.
7	Over voltage test	ISO 16750-2-2010	Room temperature, 24V, over voltage 60s, meet functional state A.
8	Reversed voltage	ISO 16750-2-2010	Work mode3.2, -14V supply, 60s, meet functional state C。
9	Slow decrease and increase of supply voltage	ISO 16750-2-2010	Usmin-0-Usmin, 0.5V/min, in Usmin voltage, meet functional state B. in other voltage meet functional state C..
10	Short circuit test	ISO 16750-2-2010	Short circuit time 60s, short to Usmax and GND, meet functional state C。
11	Superimposed alternating voltage	ISO 16750-2-2010	Usmax=16V, Upp=4V, frequency range 0.05~20KHz, meet functional state A.



12	Conducted immunity to pulses on LV supply lines - Pulse 1	GB/T21437.2-2008	Test voltage-100V, pulses number 5000 ↑, pulse cycle 0.5s, meet functional state C.
13	Conducted immunity to pulses on LV supply lines - Pulse 2a	GB/T21437.2-2008	Test voltage +50V, pulses number 5000 ↑, pulse cycle 0.2s, meet functional state A.
14	Conducted immunity to pulses on LV supply lines - Pulse 2b	GB/T21437.2-2008	Test voltage +10V, pulses number 10 ↑, pulse cycle 0.5s, meet functional state C.
15	Conducted immunity to pulses on LV supply lines -Pulse 3a	GB/T21437.2-2008	Test voltage -150V, test time 1h, pulse cycle 90ms, meet functional state A.
16	Conducted immunity to pulses on LV supply lines -Pulse 3b	GB/T21437.2-2008	Test voltage +100V, test time 1h, pulse cycle 90ms, meet functional state A.
17	Conducted immunity to pulses on LV supply lines -Pulse 4	GB/T21437.2-2008	Test voltage -7V, pulse number 3, meet functional state A.
18	Conducted immunity to pulses on LV supply lines -Pulse 5b	GB/T21437.2-2008	Test voltage +79V, pulse number5, pulse cycle60s, meet functional state C.
19	Conducted immunity to pulses on other than supply lines——fast pulses a	GB/T21437.3-2012	Test voltage -60V, CCC, injection position L2+L3, test time 10min, meet functional state A.
20	Conducted immunity to pulses on other than supply lines——fast pulses a	GB/T21437.3-2012	Test voltage +40V, CCC, injection position L2+L3, test time 10min, meet functional state A.
21	Radiated emissions from components/modules - ALSE method	GB/T 18655-2010	Horizontal polarisations meet class3, vertical polarisations meet class4.
22	Conducted emissions from components/modules – Voltage method	GB/T 18655-2010	Meet class4
23	Radiated Immunity – BCI	ISO 11452-4: 2005	modulation: CW, 80%AM(1KHz), meet functional state A.



24	Radiated Immunity -Absorber-lined shielded enclosure	ISO 11452-2: 2004	frequency 200~800MHz, field strength 100V/m, Horizontal / vertical, modulation CW, 80% AM (1KHz) ; frequency 800~2000MHz, field strength 100V/m, 垂 Horizontal / vertical, modulation PM(t=577us,T=4600us); frequency 2000~3000MHz, field strength 100V/m, Horizontal / vertical, modulation PM(t=577us,T=4600us); meet functional state A.
25	ESD	ISO 10605: 2008	Power: Contact discharge ±4KV、±6KV、±8KV、15KV Air discharge ±6KV、±8KV、±15KV、±20KV; Unpower: Contact discharge ±4KV、±6KV; Air discharge ±4KV、±8KV。 Discharge 5, meet functional state A.
26	Electrical fast transient/burst immunity test	GB/T 17626.4-2008	Test voltage ±2000V, pulse frequency 5KHz, injection time 60s, injection position L1, meet functional state B.
27	Surge immunity test	GB/T 17626.5-2008	Test voltage ±500V、±1000V, injection position L1 supply line and back line, test 5, meet functional state B.

VCU satisfy the test standards below

## 2.2 Supply conditions

### 2.2.1 Main supply design

VCU gain power from battery (Vbat) ,rotate the IG Key(Key\_ON) will turn on the internal power module of VCU and wake it up.

11. Turn off the Key\_ON, the static current less than 3mA, turn ON the Key\_ON, the work current less than 200Ma.
12. Within 9V-16V voltage, all VCU functions will meet the requirements.
13. Within 6.5V-9V voltage, VCU provide limited functions , but the functions below shall work normally
  - MCU shall work normally
  - CAN communication shall work normally
14. Within 16V-24V supply voltage, VCU shall not be damaged with in 5 mins
15. VCU shall not be damaged by reversed voltage condition in 5 mins.



16. Other than the KEY ON, VCU has a hardware wakeup port, which can recognize pulse signal that last than 300ms.
17. VCU support CAN wakeup.
18. VCU can power down with a delay
19. VCU can power down with a delay

## 2.2.2 Sensor supply

VCU provide 2 supply power of 5V that each can source the MAX 100mA current 。 VCU has feedback of all sensors supply state and can enable the sensor supply。 VCU will disable the supply by software when fail conditions detected。 Sensor supply has protection capability to short to GND and Battery.

## 2.3 The performance of Hardware

### 2.3.1 Microcontrollers

The microcontrollers meet the needs of all safety critical automotive applications

20. Core Size: 32-Bit
21. Speed: 200MHz
22. Program Memory Size: 2MB
23. EEPROM Size: 128KB
24. RAM Size: 184KB

### 2.3.2 I/O

25. VCU includes 8 high effective digital inputs(configurable) , 8 Low effective digital inputs(configurable).
- The following Figure shows the high effective digital inputs.

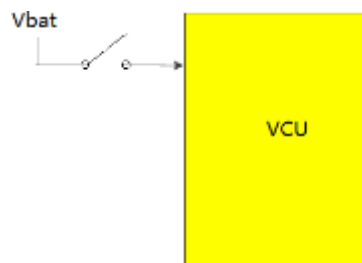

- The following Figure shows the low effective digital inputs.

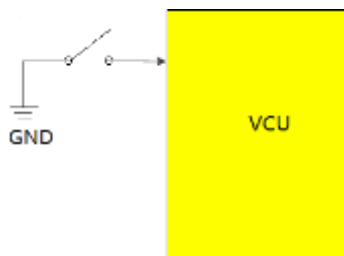

26. The Sink current of a || digital input channels is less than 1mA.
27. The unused channel must be connect to GND or VCC by resistance.
28. Each PIN have short circuit protection.



### 2.3.3 ADC

29. The controller includes at least eight analog inputs. 4 channels (0~5V), 4 channels (0~12V/0~5V).
30. Analog input signals include voltage signals and resistance signals.
31. VCU can detect battery voltage.
32. VCU provides diagnosis information about open load/ Short to ground/short-to-supply events.
33. Each PIN have short circuit protection.

### 2.3.4 Powertrain Switch

#### 2.3.4.1 Low-Side Switch

34. 1 channel,used as the Powertrain switch.
35. Output Current
  - 8 channel Output Current is Less than 2A ;
  - 3 channel Output Current is Less than 4A;
  - 7 channel Output Current is Less than 2A .
36. VCU provides diagnosis information about the device and about the load,including open load/ Short to ground/short-to-supply.
37. Each PIN have short circuit protection.

#### 2.3.4.2 Half-Bridge Switch

4 channel Output Current is Less than 0.6A.

38. provide diagnosis information about the device and about the load,including open load/ Short to ground/short-to-supply.
39. Each PIN have short circuit protection.

#### 2.3.4.3 H-Bridge Switch

40. 1 channel,can be used as the Powertrain switch of MCU.
41. Output Current is less than 5A.
42. Each PIN have short circuit protection.

#### 2.3.4.4 PWM Switch

43. 2 channel.
44. Output Current is less than 50mA.
45. Each PIN have short circuit protection.

#### 2.3.4.5 Driver of LED

46. 2 channel.
47. Output Current is less than 50mA.
48. Each PIN have short circuit protection.

## 2.4 The performance of Communication interface

### 2.4.1 CAN

49. 3 channel, Compatible of CAN2.0A/B, can be used to communication with the other unit of vehicle.
50. One channel can be active by External event.
51. Compatible of CAN2.0B ISO11898-2003.
52. Each channel have Terminating resistor.
53. Each PIN have short circuit protection.
54. providing diagnostic function.

VCU will Monitor the information of error and shutdown of CANBUS , return the state of operating.

**2.4.2 Other communication interface**

55. One channel of K-Line.

**3. Product bottom software description**

The underlying software of the controller follows the AUTOSAR architecture uses the MC-ISAR underlying driver and functional security testing library provided by Infineon. The entire underlying software is composed of a series of software functional modules with standard structure. It can be configured by external configuration software EB and meet the configurable requirements of the software. The underlying software include: microprocessor abstraction layer (IO driver, communication driver, storage driver and single chip microcomputer driver), ECU abstraction layer (IO hardware abstraction, communication hardware abstraction, storage hardware abstraction and ECU board device driver), the service layer (real-time task scheduling system, library, storage services and communications services), complex drive function library.

**4. Product software development tool chain**

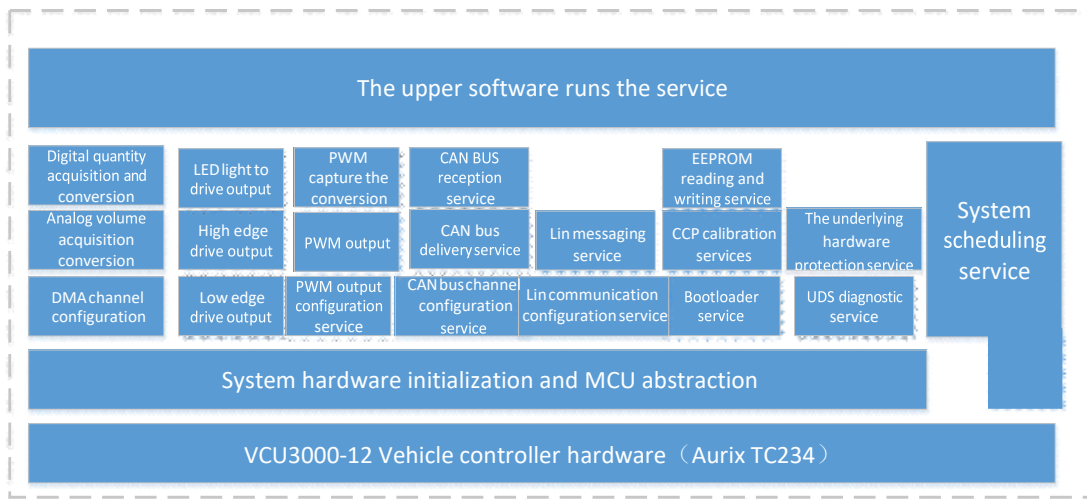

**4.1 Compiler**

The underlying software of this controller is developed and compiled in the Hightec compilation environment.



Copyright © 2015 HighTec EDV-Systeme GmbH



#### **4.2 Debugger**

Lauterbach TRACE32 or ude.

#### **4.3 Calibration**

VECTOR CANape or ETAS INCA or CANmc .

#### **4.4 Date monitoring analysis**

CANmc (developed by Yidingfeng) .

#### **4.5 Application update**

flashdown (developed by Yidingfeng) .

#### **4.6 TOOL**

CAN card (model can be USB to CAN-I+, USB to CAN-II+, USB to CAN-E-U) .