



3KW DC/DC Converter-Liquid Model No. ATD3K-640S27-W



Features

- 1 Output Power: 3KW
- 2 Input Voltage: 400~900VDC
- 3 Output Voltage: 27.5VDC
- 4 Dimensions: 298x172x86mm
- 5 Weight: ≤4.5KG
- 6 Cooling System: Liquid, flow ≥6L/min
- 7 Protection Level: IP67
- 8 Communication Method: CAN-BUS
- 9 Enclosure: Aluminum alloy
- 10 Software: Digital software design
- 11 Online Upgrade & Fault Diagnosis: Supported

Specification

Description	Technical Specification	Remark
Operating Temperature	-40~85°C	Coolant inlet temperature
Rated Output Power	3KW	Peak power: 3.6KW
Input Voltage Range	400~900VDC	
Rated Output Voltage	27.5VDC	Adjustable
Rated Output Current	110A	
Auxiliary Voltage Range	9~32VDC	VCC
Efficiency	≥95%	Rated voltage, specific load
Output Voltage Ripple	≤500mV _{PK-PK}	
Output Voltage Accuracy	±1%	
Wakeup Method	KL15(hardwire)	
Communication Method	CAN-BUS	
Quiescent Current	≤2mA	Battery current will be consumed in sleep/standby mode
Protection Characteristics	Input OVP/UVP, output OVP/UVP, input anti-reverse connection, output short circuit protection, OCP, OTP	
EMC	GB/T 18655-2010	



3KW DC/DC Converter-Liquid Model No. ATD3K-640S27-W

Structural Parameters (unit : mm)

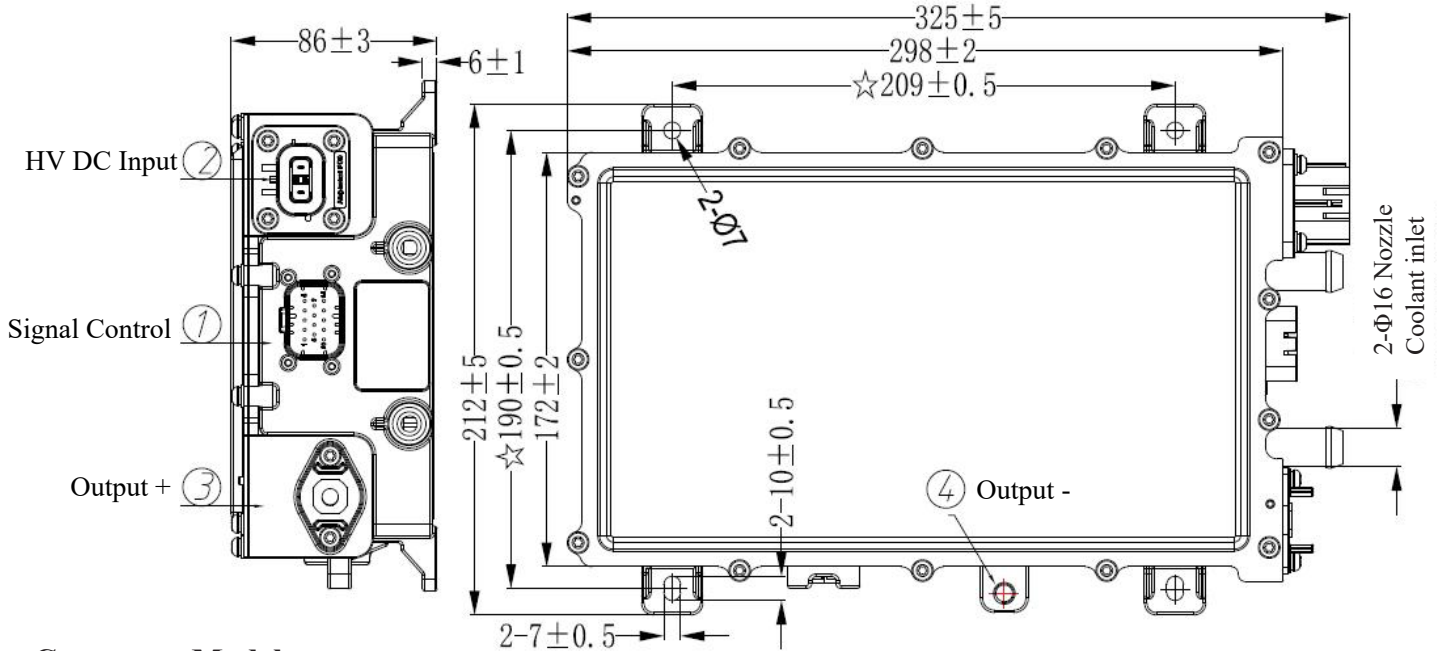

Connector Model

Position	Function	Brand	Socket Model	Plug Model
1	Signal control	Gvtong	GVT03-RS013-14-L02	GE01-P008-14NNB-Y01
2	HV DC input	Amphenol	HVSL282022FND	HVSL282062F104IND
3	Output +	Gvtong	GH17-F200-1NNB-T01	M8 Screw
4	Output -	/	M8 Bolt	M8 Screw

Interface Definition

Signal Control(1)		HV DC Input(2)		Output Positive(3)	
1	CAN-H	1	Input +	+	Output +
2	CAN-L	2	Input -		
3	KEY (connect ON)	A	HVIL_IN		
4	VCC + (connect to power supply)	B	HVIL_OUT		
5	GND				
6	HVIL_IN				
7	HVIL_OUT				
8	NC				