



Input DC 570~680V 3KW DC/DC Converter Module Model No. ATRD3K-615S24M

	<p>Features</p> <ol style="list-style-type: none"> 1. Output Power(KW): 3 2. Input Voltage Range(VDC): 570-680 3. Rated Input Voltage(VDC): 615 4. Output Voltage Range(VDC): 0~32 5. Rated Output Voltage(VDC): 24 6. Output Current Range(A): 0~109 7. Communication: CAN2.0 B SAE J1939 8. Hard Ware Isolated: Supported 9. Software: Digital software design 10. Online Upgrade & Fault Diagnosis: Supported
<p>3D file no: 901.20070000.00 Module no.: 2007-01</p>	

2. Electrical Characteristics

2.1 Electrical Characteristics

Input and output characteristics	
Input pre-charge circuit	built-in
Input pre-charge resistance	120R
Bus Capacitor	12uF
Voltage regulation accuracy V	± 2%
Output response time	≤200mS
Typical efficiency	≥93%
Protection features	
Over-voltage and under-voltage protection	The input over-voltage or under-voltage shutdown can be self-recovered, and the output over-voltage or under-voltage shutdown can be self-recovered.
Output reverse connection and short circuit protection	Shutdown when output is short-circuited or reverse connected, self-recovery
Over temperature protection	When the heat sink temperature is higher than 75°C, the output power is reduced. When the temperature is higher than 95°C, the circuit is disconnected. The charger resumes output when the charging temperature returns to below 85°C.



Environmental conditions		
Operating temperature	-40°C~+85°C (internal temperature of integrated system cavity); Water cooling system liquid temperature ≤65°C	
Storage temperature	-40~95°C	
Cooling function	Modular design, water cooling or air cooling housing/substrate required	
Communication function	CAN bus	
Control method	No enable control; hard line high level enable control; CAN communication enable control	
Safety features		
Dielectric strength	Primary side - secondary side 2800VAC	Primary side - case 2800VAC
Insulation resistance	Primary side - secondary side ≥50MΩ	
Vibration resistance	After the X, Y, and Z direction sweep frequency vibration test, the parts were not damaged and the fasteners were not loose.	
Impact resistance	Refer to the requirements of 6.5 in GB/T15139-1994	
Industrial solvent resistance	Metal parts have good anti-corrosion layer	
Anti-salt spray performance	See GB/T 2423.17	
Durability	At no less than the relevant provisions of GB/T 24347-2009	
EMC characteristics		
Electromagnetic immunity	Meet the requirements of Chapter 4 of GB/T17619-1998	
Electromagnetic disturbance	See the limits specified in Chapter 12 and Chapter 14 of GB18655-2002	

3. Dimensions and weight

3.1 Product size

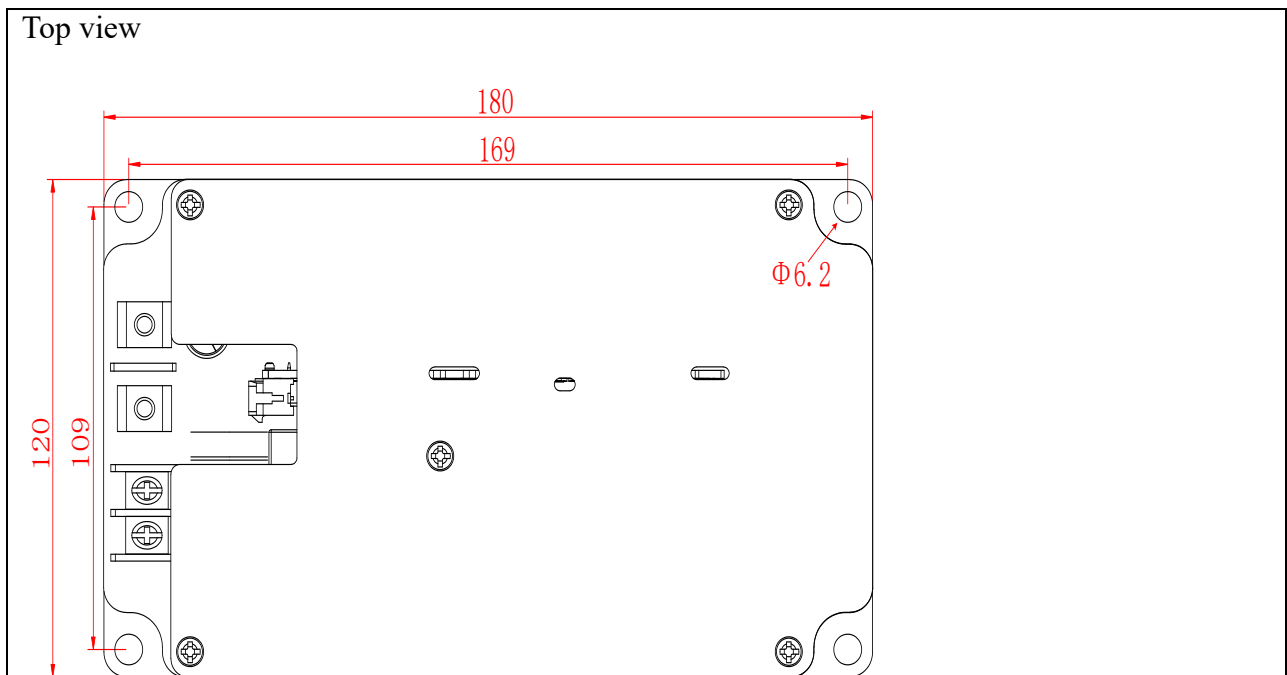

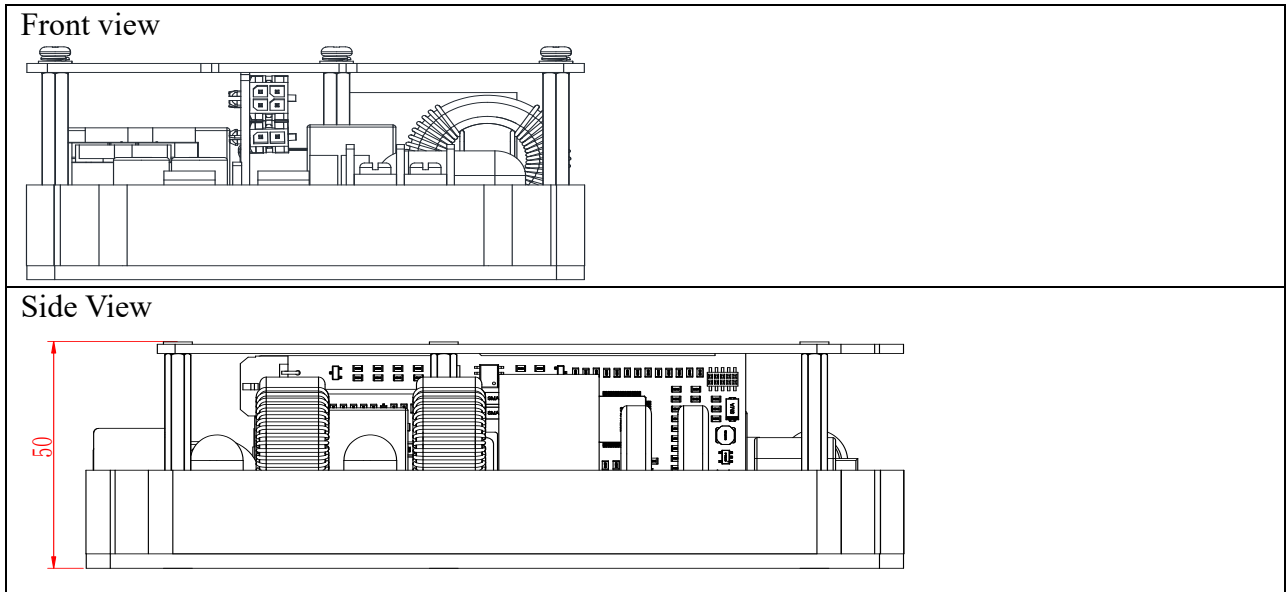

3.2. Product Weight

1.8Kg±0.3Kg

4. Definition of connector and connection terminals

4.1. Power Port Definition

Power Port Definition					
NO.	definition	Pin Description	Connector Specifications		Recommended connections
1	VO+	DC-DC output positive terminal		spacing: 11.00mm Screw hole diameter: M8 Screw torque: 8N·m	Copper busbar
2	VO-	DC-DC output negative terminal			
3	VI+	DC-DC input positive terminal		spacing: 5.00mm Screw hole diameter: M4 Screw torque: 18 Kgf/cm ²	OT terminal/ Copper busbar
4	VI-	DC-DC input negative			



4.2 Signal port definition

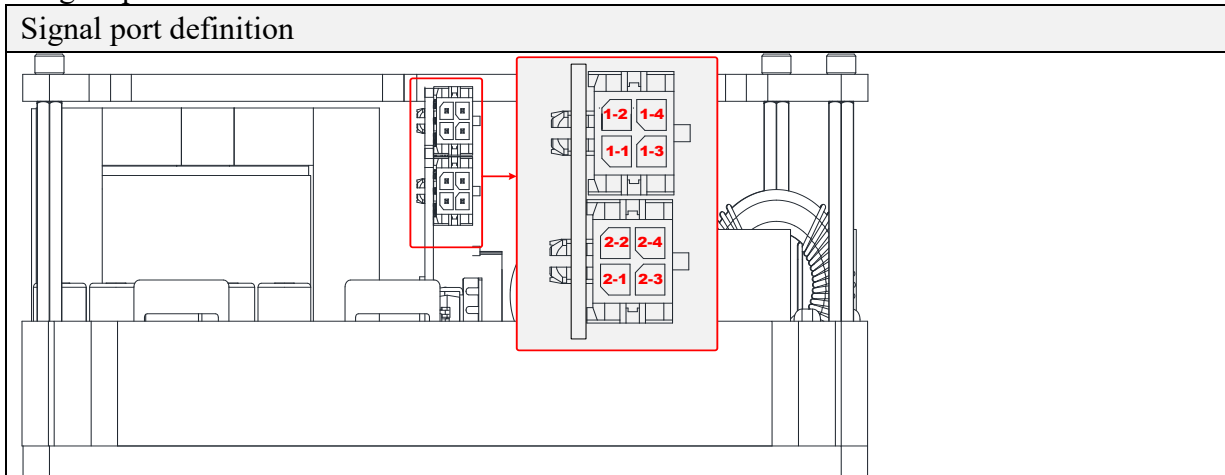

Pinout	definition	Pin Description	
①	1	CAN-L	CAN- Low signal
	3	CAN-H	CAN- High signal

	2	Enable input	Hardwire enable signal input (8-32V)
	4	12V-OUT	12V wake-up signal output
②	1	FAN- 12V0.3A	12V/0.3A fan driver negative
	2	FAN+ 12V0.3A	12V/0.3A fan driver positive port
Note: None			

4.3.

Definition and selection of signal connectors				
4-core signal connector	4-pin plug-in connector	2-core signal connector	2-pin plug-in connector	Terminal core
Default signal connector selection 【MOLEX】				
0430450400	0430250400	0430450200	0430250200	430300001
Domestic alternative models [Dongguan Yuliang Electronics Co., Ltd.]				
YL009-047-004	YL009-047-A04	YL009-047-002	YL009-047-A02	YL009-047
Domestic alternative models [Dongguan Kangdao New Energy Technology Co., Ltd.]				
23001W90-2*2PA-A1-SN	23001H-2*2PA-66	23001W90-1*2PA-A1-SN	23001H-1*2PA-66	23001TOP-SN
Domestic alternative models [Zhejiang Hongxing Electric Co., Ltd.]				
HX30002-4WA	HX30002-4P	HX30002-2WA	HX30002-2P	HX30001-PT

Signal interface schematic diagram

Signal Description



communication

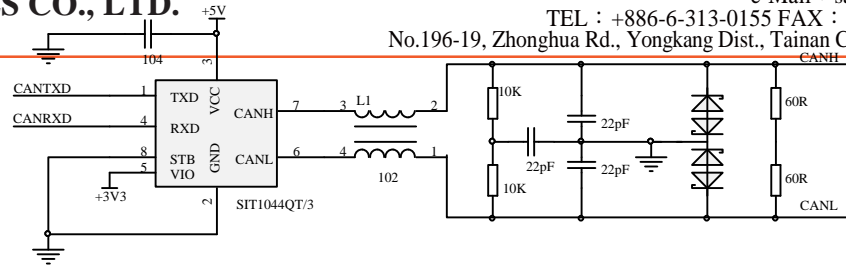

Fan drive

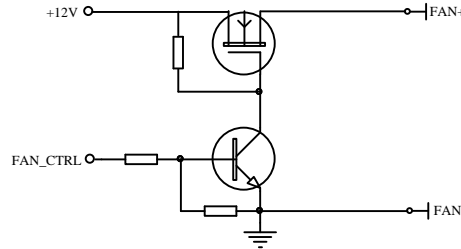

5. User Guide

5.1 Electrical Connection

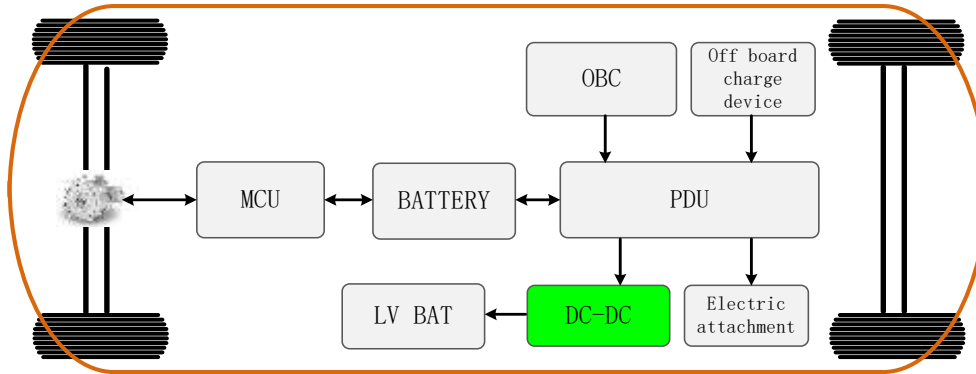

5.2. Product Installation

- 5.2.1 Flatness of mounting table: The flatness of the power mounting table must be $\leq 0.2\text{mm}$.
- 5.2.2 Thermal conductive material: Apply thermal conductive silicone grease to the bottom of the power supply heat sink. The thermal conductivity of the silicone grease should be $\geq 1.0\text{W/m.K}$.
- 5.2.3 Clean the installation surface: The bottom of the power supply heat sink and the corresponding power supply mounting platform surface are clean and free of foreign matter.
- 5.2.4 Stencil printing: Use stencil printing to apply thermal grease to the bottom of the power supply heat sink.

The recommended steel mesh thickness is 0.45mm, and the window opening rate is about 50% (square window is 4.5mm*4.5mm, with a spacing of 1.8mm). As shown in the figure.

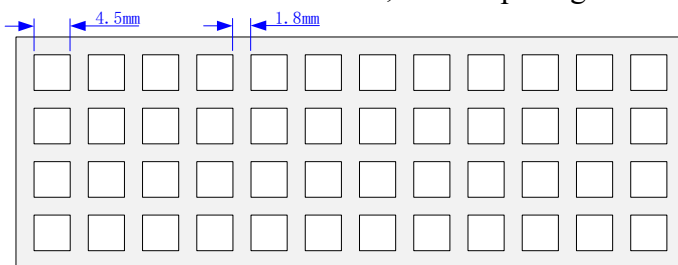

- 5.2.5 After printing the thermal grease on the bottom of the power supply heat sink, place the power supply on the mounting table, apply appropriate pressure, and move the power supply slightly back and forth and left and right to evenly distribute the thermal grease and fill the gaps.



5.2.6 viii. Align the mounting holes, tighten the fixing screws, and secure the power supply. The number of screws and recommended screw types are shown in the following table.

Mounting Screws	Mounting hole diameter	Φ6.2
	Number	4
	Recommended screw type	M5 hexagon socket combination screw

5.2.7 Tightening torque requirements: Use appropriate torque for installation based on screw size, connection method, etc. See the table below for details:

Specifications		Tightening torque (torque range: ±10%)/(unit: Kgf.cm)						
Major categories	Subclass	Plastic-Plastic	Steel-Plastic Copper-Copper	General Connections		High density connection		
				Steel-Steel	Copper-cast aluminum Steel-aluminum profile	Steel-Steel	Steel-cast aluminum Steel-copper	Steel-Aluminum Profile
Hexagon socket screw	M3	1.5	3	5.5	5	10	8	6
	M4		6	12	10	16	14	12
	M5		10	20	13	30	28	20
	M6		15	30	28	50	48	30
	M8					80	80	-

5.3. Thermal Design Guidelines

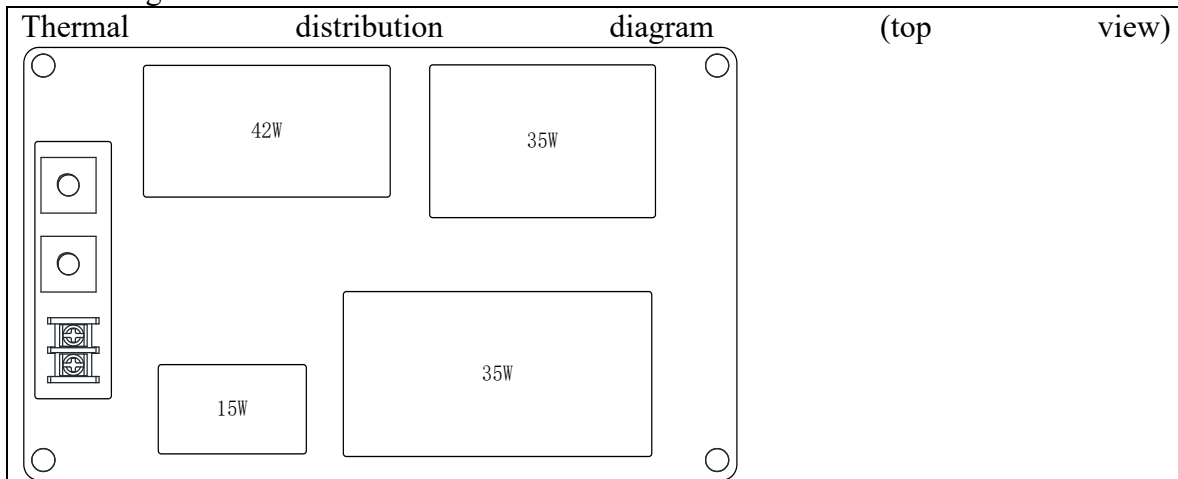



The bottom surface is a heat dissipation surface and must be in touch with the shell. The shell must be even and can not be painted. It must be metal and must be evenly coated with thermal grease. Unmentioned matters should be communicated in time.

→

- ① The heat dissipation shell can be designed through theoretical calculation or thermal simulation, and the actual measurement of the point temperature meter shall prevail.
- ② At rated input and rated output, the maximum temperature of each point on the radiator surface minus the ambient temperature should be $\leq 40^{\circ}\text{C}$ after 1 hour.
- ③ The heat dissipation contact surface between the radiator and the module should be flat, smooth, free of foreign matter and oil. The contact surface should be seamless when placed naturally.
- ④ If the radiator is a cast aluminum part, the contact surface between the radiator and the module aluminum groove must be CNC processed to ensure good contact.
- ⑤ The contact surface between the modular radiator and the module should be evenly coated with silicone grease in an appropriate amount.
- ⑥ When designing the radiator, ensure that the thickness of the radiator at the contact surface between the module and the radiator is greater than or equal to 4mm.









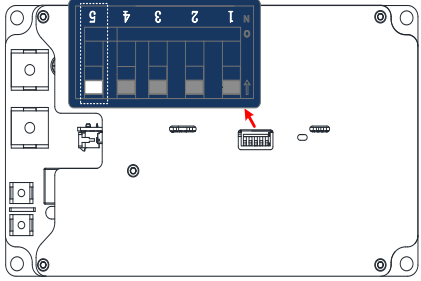

5.4. CAN Communication Protocol

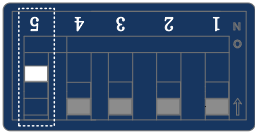
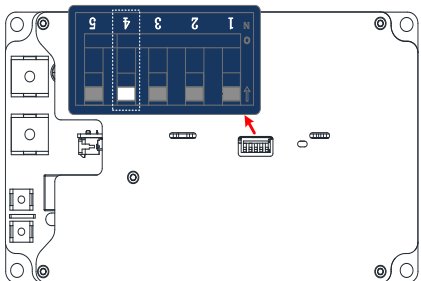
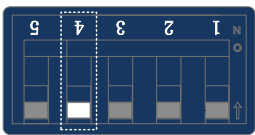
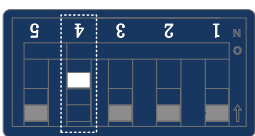
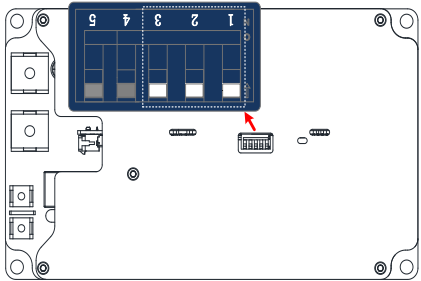
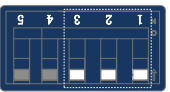
project	Technical indicators	Remark
Crystal tolerance	$\pm 0.15\%$	In the operating temperature range
Communication rate	Configurable through background software, configuration will not be lost after power failure	Tolerance is ± 0.375 Kbit/s
Sampling point	The sampling point should be set close to but not later than 7/8 of the bit time.	
Transceiver	Maximum transceiver "ring delay" (from transmit to receive) is 300 ns	CAN transceivers should comply with ISO 11898-2 standard
Terminal resistance	The DC-DC CAN communication circuit has a 120 ohm terminal resistor by default.	
Default communication protocol	CAN	TBD



5.5 Multi-machine parallel operation instructions

The DCDC module has its own CAN bus current sharing logic, which can achieve current sharing without master-slave for up to 8 units. The current sharing modules must be of the same model, and the addresses must be assigned through the DIP switches on the modules. The DIP switch positions and address assignment tables are as follows:

<p>Dip switch 5</p> 	Dip switch position		GND	
			Enable signal GND connected with KL31	
			Enable signal GND disconnected with KL31	
	Dip switch position		120R resistor	
<p>Dip switch 4</p> 			DCDC CAN bus without 120R resistor	
			DCDC CAN bus with 120R resistor	
<p>Dip switch 3 2 1</p> 	Position	Address	Position	Address
		0		4
		1		5
		2		6
		3		7

5.6 Background debugging software description

Backend software coding	2001 Setup V2.0	
Backend software communication method	CAN communication	Baud rate 125K/250K/500K adjustable



Installation and usage help		 上位机使用说明.pdf
Support CAN box Brand 1	1. Beijing AiTai USBCAN-2I 2. Beijing AiTai USBCAN-I	 USBCAN Driver for Windows 10-amd64-1.0.1.exe
Support CAN box Brand 2	TBD	

5.7 Troubleshooting and confirmation

Fault phenomenon	Common causes of failure	troubleshooting
No power output	High voltage input is abnormal (no or reverse connection)	Check whether the high voltage input is normal
	12V voltage input port is abnormal (no voltage, over/under voltage, reverse connection)	Check whether the 12V voltage input port is normal
	Output disconnection	Check if the output connection is normal
DC-DC No message	The signal connector is not connected properly	Reseat the signal connector
	CAN line is connected reversely	Adjust the CAN line sequence
	Communication protocol does not match	Compare whether the protocols match
	Baud rate mismatch	Compare baud rates to see if they match
The high voltage input fuse of the power distribution box is damaged. The product reports a fault signal.	Input short circuit	Check whether the high voltage input is normal
	Input over/under voltage, output over/under voltage, over temperature, output short circuit/over current	Check input voltage, output for overcurrent/short circuit, turn off power, let stand for 10 minutes, if still faulty, contact the manufacturer.
Over temperature fault	Air-cooled machine: fan is blocked or air duct is blocked	Check the fan and air duct
	Water-cooled machine: no coolant or coolant temperature is too high	Check whether the coolant is normal

5.8 . Fault Judgment Criteria and Handling Methods

Fault phenomenon	Common causes of failures	Troubleshooting
The power supply has no output	High Voltage Input Exception (None or Reverse)	Check if the high-voltage input is normal
	12V voltage input port is abnormal (none, over/undervoltage, reverse connection)	Check whether the 12V voltage input port is normal



	The output is disconnected	Check whether the output connection is normal
No packets are sent from DC-DC	The signal connector is not properly connected	Reseat the signal connector
	The CAN cable is reversed	Adjust the CAN line sequence
	The communication protocol does not match	Compare whether the protocols match
	Baud rates don't match	Compare whether the protocols match
The distribution box high voltage input fuse is damaged The product reports a fault signal	Input short circuit	Check if the high-voltage input is normal
	Input over/undervoltage, output over/undervoltage, overtemperature, output short-circuit/overcurrent	Check the input voltage, output for overcurrent/short circuit, turn off the power, let stand for 10 minutes, if it still fails, contact the manufacturer.
Overtemperature failure	Air-cooled machines: The fan is stalled or the air duct is blocked	Check the fan and air duct
	Water-cooled machines: No coolant or too high coolant temperature	Check that the coolant is normal

6 User Instructions and Precautions

Please pay attention to the warning and precautions before using the product. Improper operation may cause electric shock damage or fire. Please make sure you have read the warnings and precautions before using the product.

Warning:

It is strictly forbidden to disassemble the product for repair, debugging, and modification without authorization;

When the power is on, please keep your hands and face away from the product to avoid accidental injury; There is high voltage and high temperature inside the product. Please do not touch the internal components, which may cause electric shock or burns;

During use, if the power supply has abnormal sounds or odors, please turn off the input immediately; Connectors that meet the specifications must be used to ensure that each plug and socket is tightly connected. Looseness may cause local heating and fire;

Please use the power supply within the technical parameters. If it is used beyond the range, it may cause product damage;

Please avoid placing the product in a rainy place for a long time;

Please make sure that the casing is intact before installation. If it is damaged, please replace it immediately or contact the manufacturer.

Notes:

Confirm that the product input/output terminals and signal terminals are correctly connected according to the product manual; when wiring, please cut off the input power and never plug or unplug the connector with power on;

This power input/output terminal requires an external fuse or other overcurrent protection device;

The possible electrical hazards at the output terminal when the product is used must be considered to ensure



that the end product user will not touch the product; the terminal equipment manufacturer must design a corresponding protection plan to ensure that there will be no danger due to accidental contact between the power terminal by engineers or tools during operation;

Once the safety protection of the equipment is damaged, the equipment must be stopped and handled in accordance with relevant maintenance regulations.

When the power supply equipment is transferred from a cold environment to a warm environment, condensation may cause leakage hazards, so the grounding requirements must be strictly enforced;

Only qualified personnel can connect the equipment to the power supply.

After cutting off the power supply, the machine must be shut down for five minutes to allow the capacitor to have sufficient discharge time before the power supply equipment can be maintained.

Pay attention to safety in use: avoid touching with your hands where there are safety warning signs and high-voltage signs to avoid electric shock and burns.

7.Reference standards and specifications

GB 14023-2011 Limits and methods of measurement of radio disturbance characteristics of vehicles, ships and devices driven by internal combustion engines

GB/T 17626.2-2006 Electromagnetic compatibility test and measurement technology Electrostatic discharge immunity test

GB/T 17626.3-2006 Electromagnetic compatibility test and measurement technology Radio frequency electromagnetic field radiation immunity test

GB/T 17626.4-2008 Electromagnetic compatibility test and measurement technology Electrical fast transient pulse group immunity test

GB/T 17626.5-2008 Electromagnetic compatibility test and measurement technology Surge (impact) immunity test

GB/T 17619 1998 Electromagnetic radiation immunity limits and measurement methods for electronic and electrical components in motor vehicles

GB/T 18384.3-2015 Electric vehicles - Safety requirements - Part 3: Protection of personnel against electric shock

GB/T 18387-2008 Limits and measurement methods of electromagnetic field emission intensity of electric vehicles, broadband, 9KHz~30MHz

GB/T 18487.2-2001 Electric vehicle conductive charging system Electric vehicle connection requirements for AC and DC power sources (doc)

GB/T 18487.3-2001 Electric vehicle conductive charging system Electric vehicle connection requirements for AC and DC power sources (doc)...

GB/T 18488.1-2015 Drive motor systems for electric vehicles Part 1: Technical requirements

GB/T 18655-2010 Limits and methods of measurement of radio disturbance characteristics of ships and internal combustion engines for the protection of on-board receivers

GB/T 19826-2014 General technical conditions and safety requirements for DC power supply equipment in power engineering

GB/T 21437.2-2008 Road vehicles - Electrical disturbances caused by conduction and coupling - Part 2: Electrical transients conducted along power supply lines

GB/T 2423.1-2008 Environmental testing for electric and electronic products Part 2: Test methods Test A: Low temperature

GB/T 2423.2-2008 Environmental testing for electric and electronic products Part 2: Test methods Test B: High temperature

GB/T 2423.3-2006 Basic environmental test procedures for electrical and electronic products - Test Ca: Steady state damp heat test method;

GB/T 2423.4-2008 Basic environmental test procedures for electrical and electronic products - Test Db: Cyclic damp heat test method



- GB/T 2423.5-1995 Environmental testing for electric and electronic products, Part 2: Test methods/Test guidance: Shock
- GB/T 2423.6-1995 Environmental testing for electric and electronic products, Part 2: Test methods/Test guidance: Bump
- GB/T 2423.8-1995 Environmental testing for electric and electronic products, Part 2: Test methods/Test Ed: Free fall
- GB/T 2423.10-2008 Environmental testing for electric and electronic products, Part 2: Test methods/Test Fc and guidance: Vibration (sinusoidal)
- GB/T 2423.22-2012 Environmental testing for electric and electronic products, Part 2: Test N: Temperature changes
- GB/T 24347-2009 Electric vehicle DC/DC converter
- GB 4208-2008 Enclosure protection degree (IP code)
- QC/T 413-2002 Basic technical requirements for automotive electrical equipment
- GB 9254-2008 Limits and methods of measurement of radio disturbances for information technology equipment

8.Packaging, transportation and storage

Product packaging information is as follows:

Packing quantity and box information	Single module net weight Kg	1.8Kg
	External dimensions of packaging box (mm)	412*512*227
	Number of modules per box	12
	Total weight after packaging Kg	25Kg

The packaging box should have the product name, product model, and manufacturer name; the technical documents supplied with the product in the packaging box should include the product factory certificate. The product should be transported in a sturdy packaging box, and the outer packaging box should comply with the relevant national standards and should have signs such as "handle with care" and "moisture-proof". The packaging box containing the product is allowed to be transported by various means of transportation. During transportation, direct rain and snow and mechanical impact should be avoided. The transportation Mark is attached, as shown in Figure 7-2 below:



Transport mark

When the product is not in use, it should be stored in the packaging box. The warehouse environment temperature is -10-40°C and the relative humidity is not more than 80%. No harmful gases, flammable and explosive products and corrosive chemicals are allowed in the warehouse. There is no strong mechanical vibration, impact and strong magnetic field. The packaging box should be at least 20cm above the ground and at least 50cm away from the wall, heat source, window or air inlet. The storage period under these conditions is generally 2 years. After more than 2 years, it should be re-inspected.

The product should be stored in a ventilated and dry place. At the same time, it must be kept away from high temperature sources, fire sources and chemicals. Store neatly and avoid throwing and smashing.