

Battery swap Connector PFSC-TQA-BS1270/PFSC-TQA-CP1270

Describe

- Floation: X,Yway: $\pm 5\text{mm}$; Zway: 0—10mm
 - High voltage terminal 2; grounding terminal 1; signal terminal 10; low voltage auxiliary power supply 2
 - More than 5000 plug-in life
 - High Protection Degree: IP67
 - Compatible with Battery Shielding
- Main use For battery pack, PDU equipment



Application

- Current Rating: 300A
- Voltage Rating: 750V DC
- Shield: Option
- HVIL: Option
- Temperature: -40°C — $+125^{\circ}\text{C}$

Hole SIZE

Battery end panel hole size

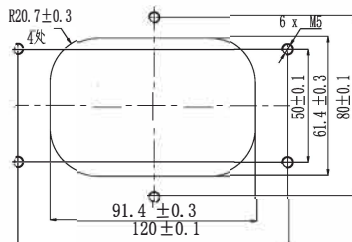

Car end panel hole size

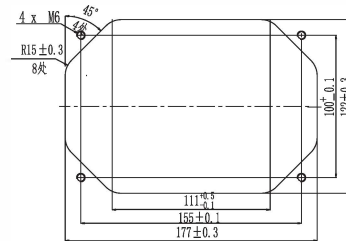

Dimensions of connector

Dimensions of Battery

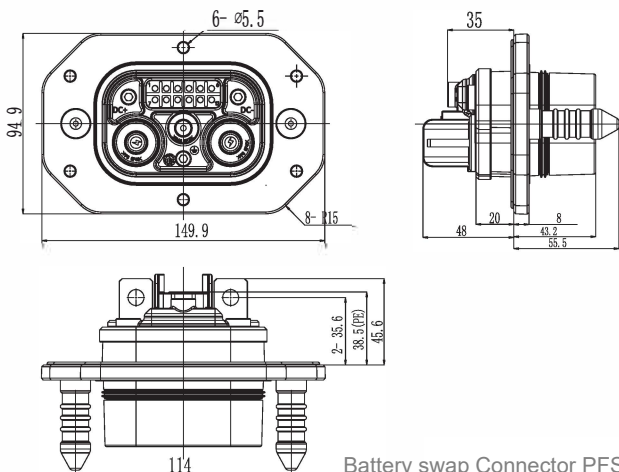

Dimensions of Car

