

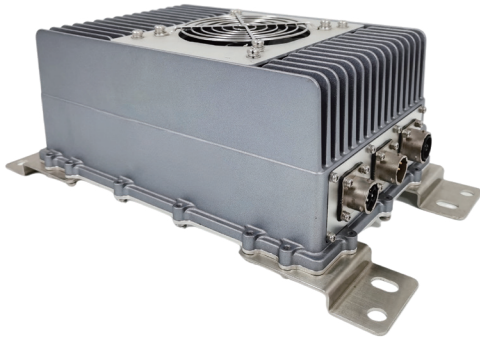

1.5KW DC/DC Converter-Fan Model No. ATD1K5-380S14-A



Features

- 1 Output Power: 1.5KW
- 2 Input Voltage: 250~450VDC
- 3 Output Voltage: 13.8VDC
- 4 Dimensions: 262x180x120mm
- 5 Weight: ≤3KG
- 6 Cooling System: Fan
- 7 Protection Level: IP67
- 8 Communication Method: CAN-BUS
- 9 Enclosure: Aluminum alloy
- 10 Software: Digital software design

Specification

Description	Technical Specification	Remark
Operating Temperature	-40~85°C	Air inlet ambient temperature
Rated Output Power	1.5KW	Peak power: 1.8KW
Input Voltage Range	250~450VDC	
Rated Output Voltage	13.8VDC	Adjustable
Rated Output Current	109A	
Auxiliary Voltage Range	9~18VDC	VCC
Efficiency	≥95%	Rated voltage
Output Voltage Ripple	≤500mV _{PK-PK}	
Output Voltage Accuracy	±1%	
Wakeup Method	CAN, hard wire, high voltage	
Communication Method	CAN-BUS	
Quiescent Current	≤2mA	Battery current will be consumed in sleep/standby mode
Protection Characteristics	Input OVP/UVP, output OVP/UVP, input anti-reverse protection, output short circuit protection, OCP, OTP	
EMC	GB/T 18655-2010 Class 3	



1.5KW DC/DC Converter-Fan Model No. ATD1K5-380S14-A

Structural Parameters (unit : mm)

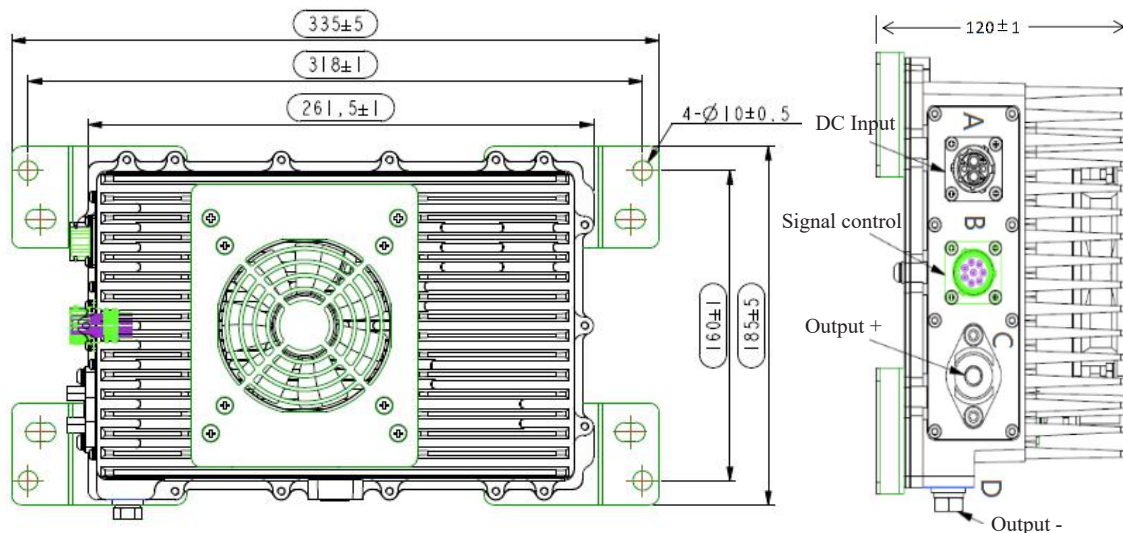

Connector Model

Position	Function	Brand	Socket Model	Plug Model
A	DC Input	Amphenol	RT00122PN03	RT06122SNHEC03
B	Signal control	Amphenol	RT00128PN03	RT06128SNHEC03
C	Output +	Gvtong	GH01-F200-1NNB-T21	M8 Screw
D	Output -	/	M8 Bolt	M8 Screw

Interface Definition

DC Input(A)		Signal Control(B)		Output Positive(C)	
A	Input +	A	NC	+	Output +
B	Input -	B	CAN-L		
1	NC	C	CAN-H		
2	NC	D	Shielded wire		
		E	GND		
		F	NC		
		G	NC		
		H	Enable		