



6.6KW OBC-Liquid Model No. ATC6K6-220S640-W



Features

- 1 Output Power: 6.6KW
- 2 Input Voltage: 85~265VAC
- 3 Output Voltage: 450~750VDC
- 4 Dimensions: 326x211x83mm
- 5 Weight: ≤8KG
- 6 Cooling System: Liquid, flow rate ≥6L/min
- 7 Protection Level: IP67
- 8 Communication Method: CAN-BUS
- 9 Enclosure: Aluminum alloy
- 10 Software: Digital software design
- 11 Online Upgrade & Fault Diagnosis: Supported

Specification

Description	Technical Specification	Remark
Operating Temperature	-40~85°C	Coolant inlet temperature
Rated Output Power	6.6KW	
Input Voltage Range	85~265VAC	
Rated Output Voltage	450~750VDC	
Rated Output Current	12A	
Auxiliary Voltage Range	9~32VDC	VCC
Efficiency	≥94%	Rated voltage
Voltage Accuracy	±1%	
Current Accuracy	±3%	
Low Voltage Wakeup	200mA max (wakeup signal)	Wakeup BMS/VCU, voltage follows the VCC
Wakeup Method	AC, PP/CP, EN(hardwire)	Support reservation charging
Communication Method	CAN-BUS	
Quiescent Current	≤2mA	Battery current will be consumed in sleep/standby mode
Protection Characteristics	Input OVP, UVP, output OVP, UVP, OTP, OCP, output short circuit protection, communication fault protection	
EMC	GB/T 18387-2008, EN 55022	



6.6KW OBC-Liquid Model No. ATC6K6-220S640-W

Structural Parameters (unit : mm)

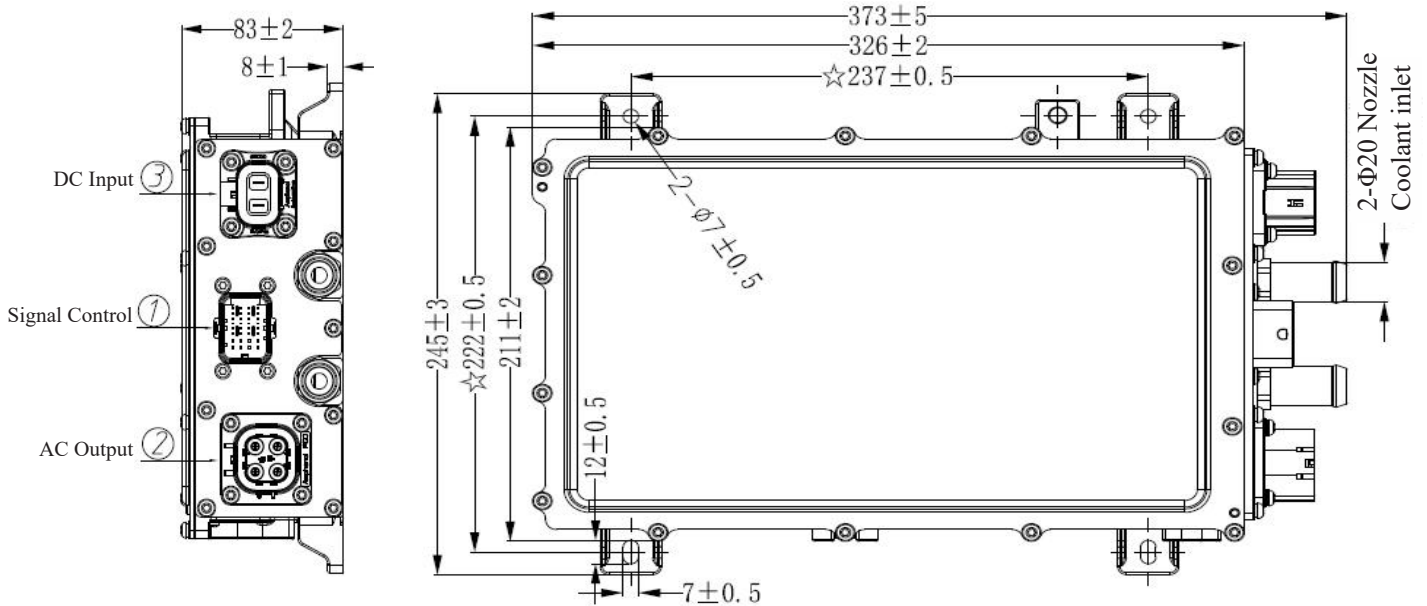

Connector Model

Position	Function	Brand	Socket Model	Plug Model
1	Signal control	TE	2334366-2	2137299-8
2	AC Input	Amphenol	HVSL364024A	HVSL364064A106I
3	DC Output	Amphenol	HVC2P63MV406	HVC2P63FS406

AC Input(2)		DC Output(3)		Signal Control(1)							
1	L	1	Output +	1A	CAN 1-H	2A	Wakeup	3A	NTC 1 +	4A	HVIL_IN
2	NC	2	Output -	1B	CAN 1-L	2B	PP_OUT	3B	NTC 2 +	4B	HVIL_OUT
3	NC	A	HVIL_IN	1C	EN_OBC	2C	NC	3C	NC	4C	NC
4	N	B	HVIL_OUT	1D	NC	2D	NC	3D	NTC 1 & 2 -	4D	NC
A	HVIL_IN			1E	PP_IN	2E	NC	3E	Lock feedback 1	4E	NC
B	HVIL_OUT			1F	CP	2F	NC	3F	Lock feedback 2	4F	NC
	Ground to chassis			1G	VCC +	2G	NC	3G	Lock +	4G	NC
				1H	GND	2H	NC	3H	Lock -	4H	NC